

Jurnal_Scopus.pdf

by

| | | | |
|----------------|--------------------------------|-----------------|-------|
| FILE | JURNAL_SCOPUS.PDF (1.83M) | WORD COUNT | 5276 |
| TIME SUBMITTED | 21-DEC-2019 11:47AM (UTC+0700) | CHARACTER COUNT | 26810 |
| SUBMISSION ID | 1237696741 | | |

The Impact of the Injection of Wind Power Plant on the Steady State Condition and the Dynamics of SULSELBAR Power System

Indar Chaerah Gunadin¹, Eka Sanjaya Putra Az¹, Yusri Syam Akil¹, and Steven Humena²

¹Department of Electrical Engineering Hasanuddin University, South Sulawesi, 92171, Indonesia

²Department of Electrical Engineering Ichnan Gorontalo University, Gorontalo, 96115, Indonesia

Email: indarcg@gmail.com; eka.unhas14@gmail.com; yusakil@unhas.ac.id; steven.humena@gmail.com

Abstract—An Injection of a renewable energy generator will cause a change in power flow in the existing system and can affect the overall system stability. With the injection of new generator, an evaluation of the power system needs to be done to update data in relation to condition of power system. In this study, simulations of steady state analysis dynamic stability were carried out which included rotor angle stability, frequency stability and voltage stability, as well as critical clearing time to evaluate the impact of Jenepono Wind Power Plant (WPP) injection on SULSELBAR power system performance in Indonesia. The steady state analysis results show that voltage profile of the system has improved and reduced active power losses of 0.11%, reactive power of 0.12% after injection of the WPP. Next, dynamic stability analysis shows recovery time of the rotor angle, frequency and voltage can return to the steady state condition after experiencing interference with duration of 0.823 sec. The critical clearing time after the WPP injection is longer the duration of the interruption, i.e. the duration of the interruption time 0.1889 sec the rotor angle experienced synchronous release.

Index Terms—steady state and dynamic stability, critical clearing time, SULSELBAR power system, Wind Power Plant (WPP)

I. INTRODUCTION

Renewable energy is the type of an alternative energy that can be used to replace the natural energy in the earth [1]. Natural fuels on earth cannot be easily obtained. This is due to the process of formation of earth energy that has lived for hundreds of thousands of years [2]. Therefore, we need a new energy source that can be used without fear of exhaustion. Indonesia can be an excellent place to develop alternative energy. With Indonesia's rich nature, it is very easy to find a variety of energy sources that are more environmentally friendly [3].

In particular, the regions in the SULSELBAR power system have many potential renewable energy sources, such as biomass energy, water, wind and sun that need to be developed in order to meet the demand for long-term electrical energy needs [4], [5].

Electricity needs in the SULSELBAR power system are mostly located in the southern part of the city, in the city of Makassar and its surroundings, while the potential for generating renewable energy is in the northern and central parts of the region. This condition becomes a separate problem related to the stability of the system because the transmission that connects the power plant to the center of the load is very long. Based on the Power Supply Business Plan (RUPTL) PT.PLN (Persero) Year 2018-2027 regarding utilization of renewable energy for electricity generation, the power utility which manage SULSELBAR power system will construct a new WPP in Jenepono regency (60 MW) [6].

Power systems need to be operated with established standards. Therefore, it is necessary to plan power systems and operate power systems properly [7]. Planning the development of a power system will involve the problem of how to design power plants, transmission and distribution channels that are tailored to future energy needs. As an initial plan, it is necessary to estimate the burden in the medium term (around 5-10 years). The type of plant that will be built must be determined [8].

WPP injection will cause a change in power flow in an existing system, and will affect the overall system stability [9]. With the WPP injection an evaluation of the power system needs to be done to update the system data [10], [11]. This data is useful in the operation of the system as well as in the design of power system development in the future. The existence of variations in load and disruption in the system will affect the system stability and the dynamic response of scattered plan. Therefore, an analysis of the system needs to be done to determine the effects that arise on the system.

To dealing with the situation above steady state and dynamics analysis can be performed. Research works in this area has been done by many researchers to evaluate penetration of renewable energy power plant at certain power system using various methods or solutions such as in [12]. As in [13], steady state and dynamic analysis studies are used as a basis for future power system development planning and important to evaluate condition of existing power system.

Manuscript received February 18, 2019; revised April 26, 2019; accepted April 30, 2019.

Corresponding author: Eka Sanjaya Putra Az (email: eka.unhas14@gmail.com).

In this research, we focus to analyze the effect of WPP injection that arises on SULSEP 18 AR power system in Indonesia. For this purpose, power flow analysis is initially done to determine the voltage profile and power loss that might occur in the system [14]. Next, steady state analysis and dynamic analysis in the form of rotor angle stability, frequency stability and voltage stability before and after injection of WPP Jenepono is carried out to find out system performance in the event of a fault [15].

7 II. POWER SYSTEM STABILITY

The stability of a system physically refers to the ability of the system to return to its initial equilibrium position in the event of a disturbance or point to a new equilibrium that generally approaches the old balance point [16]. Disruptions that occur can be minor disturbances or large disturbances that can make the system unstable [17]. The characterization of the power system at the time of the steady state before the disruption will determine the dynamic behavior of a system. Stimulation of the system that will cause the transient or permanent isolation will affect the system as a whole. Therefore, dynamic analysis of the system can help in providing a robustness of a system to return to its normal state after a disturbance occurs, which further stabilizes the power level of the power system [18]. Analysis of generator injection in the power system has also become a major concern of researchers including injection in the distribution system in the form of scattered generators injection with renewable energy [19]-[21]. The impact of the generator injection is spread in transmission stability [22], not so noticeable at low power concentration. But in large penetration, the impact is not limited to the distribution network but starts to affect the entire system including the transmission system. The level of penetration of the scattered generator affects the stability system in the transmission system [23].

18 A. Steady State Analysis

Power flow analysis is an analysis that is used to determine voltage, current, active power and reactive power in various points in a power network in the case of normal operation. In addition to being used for future power system development planning, it can also be used to evaluate the existing power system conditions [24]. As commonly known, bus in a power network has four parameters, namely active power (P), reactive power (Q), magnitude (V), and voltage angle (δ) which the buses are grouped into three types, namely reference bus (slack bus), generator bus, and load bus. Next, the performance equation of the power system can be generally expressed as an admission form as follows [15]:

$$I_{\text{bus}} = Y_{\text{bus}} V_{\text{bus}} \quad (1)$$

where I_{bus} is the current of the injection bus (A), Y_{bus} is the admittance matrix (S), and V_{bus} is the bus voltage (V).

The flow injection on a bus p can be formulated by

$$I_p = \sum_{q=1}^n Y_{pq} V_q \quad (2)$$

2 where I_p is the current on bus p , V_q is the voltage on bus q , Y_{pq} is the impedance between the bus p and bus q , and $p = 1, 2, \dots, n$.

The active power and reactive power on the bus i are

$$P_p - jQ_p = V_p I_p \quad (3)$$

or

$$I_p = \frac{P_p - jQ_p}{V_p} \quad (4)$$

2 where V_p is the voltage on bus p , P_p is the active power on bus p , and Q_p is the reactive power on bus p .

The power flow equation is solved by using the iteration process, assigning approximate values to unknown bus voltages, and calculating new values for each voltage on the bus from the other bus estimated values. To solve the power flow analysis method used in this study is the Newton-Raphson method. This method applies the modified Taylor Series to obtain the derivative of mathematical equations as the basis for an iteration calculation involving the use of the Jacobian Matrix.

With substitution Eq. (2) into (3), it is obtained

$$9 \quad P_p - jQ_p = |V_p| \angle -\delta_p \left(\sum_{q=1}^n |Y_{pq}| |V_q| \angle (\theta_{pq} + \delta_q) \right) \quad (5)$$

or

$$P_p - jQ_p = \sum_{q=1}^n |V_p| |Y_{pq}| |V_q| \angle (\theta_{pq} + \delta_q - \delta_p) \quad (6)$$

The separation of the real and imaginary parts will get the common real power equation on bus p is

$$9 \quad P_p = \sum_{q=1}^n |V_p| |V_q| |Y_{pq}| \cos(\theta_{pq} + \delta_q - \delta_p) \quad (7)$$

3 Meanwhile equation for reactive power on bus p is

$$Q_p = - \sum_{q=1}^n |V_p| |V_q| |Y_{pq}| \sin(\theta_{pq} + \delta_q - \delta_p) \quad (8)$$

B. Dynamic Stability Analysis

1) Rotor angle stability

8 In a synchronous engine, the main drive gives a mechanical torque (T_m) to the engine shaft and the engine produces electromagnetic torque (T_e). When the fault occurs, the mechanical torque is greater than the electromagnetic torque, and produces acceleration torque (T_a) as follow [25]:

$$4 \quad T_a = T_m - T_e \quad (9)$$

where T_a is the acceleration torque, T_m is the mechanical torque, and T_e is the electromagnetic torque.

For a stable system during interference, the rotor angle will oscillate around the balance point. When an interruption occurs or a sudden increase in load in large

quantities, the electrical discharge of the generator will far exceed the mechanical entry power. So the generator will spin more slowly so that the generator power angle increases and the generator's input power also increases. If the angle of rotation increases indefinitely, the machine [6] said to be unstable while the engine continues to accelerate and does not reach a new equilibrium state. In multiple machines, the machine will release synchronization with other machines. The critical clearing time is decreased if the fault location is close to the main generator or slack bus [17], [26].

20 Frequency stability

Frequency stability is related to the ability of the power system to maintain [19] frequency stability in the nominal range [27]. This depends on the ability to restore the balance between the generator system and the load, with nominal losses on the load. Electromechanical modes involving this time usually occur in the frequency range 0.1-2 Hz. The mode between regions is associated with groups of machines swing against other groups through the transmission line. Higher frequency electromechanical modes (1-2 Hz) usually involve one or two generators that swing against the entire power

system or electric engine that swings with one another.

11 Voltage stability

Voltage stability refers to the ability of a power system to keep the voltage stable on all buses in a system after experiencing an interruption to the initial operating conditions [28]. If the voltage stability is maintained, the voltage and power on the system can be controlled anytime. In general, the inability of the system to supply the necessary requirements causes voltage instability. A system enters the area of voltage instability when a disturbance causes the system to experience an uncontrollable voltage drop.

III. STUDIED SYSTEM

Steady state and dynamic stability simulation for SULSELBAR power system in this study used peak load data for the system in year 2018 (1050 MW) [29] with single line diagram obtained from PT. PLN (Persero) Makassar [4]. Selected disturbance location for dynamic stability simulation is Tallasa bus as area of the bus get interrupted system on November 11, 2017 which caused blackout system [30]. (Fig. 1).

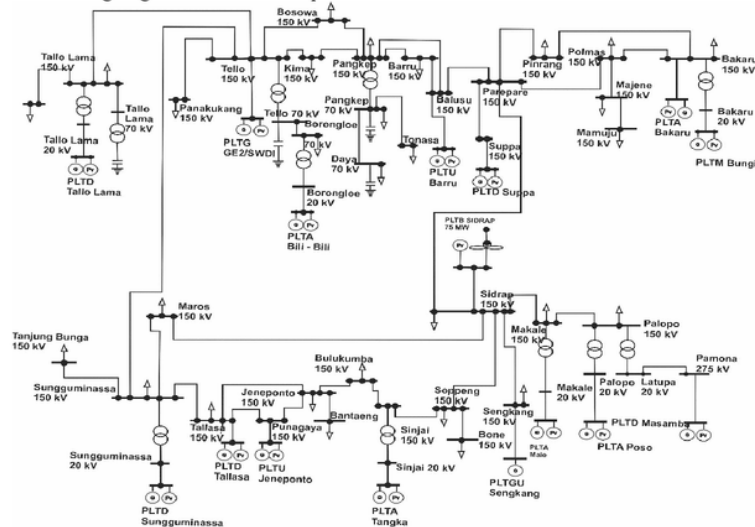

Fig. 1. Single line diagram SULSELBAR system.

C. Analysis of Steady State Conditions Before and After WPP Jeneponto Injection

WPP Jeneponto load flow simulation results in SULSELBAR interconnection power system, there is a voltage profile improvement which is located on new Bantaeng bus of 0.99 pu, Bulukumba at 0.99 pu, Jeneponto at 1 pu, Sinjai at 0.98 pu, Tallo Lama equal to 1.04 pu and voltage before injection of WPP Jeneponto, new Bantaeng bus is 0.97 pu, Bulukumba is 0.98 pu, Jeneponto is 0.98 pu, Sinjai is 0.97 pu, Tallo Lama of 1.05 pu. This happens because the addition of WPP injection to the system and the increase in [28] age is still within the allowable limit of +5%, -10% as shown in Fig. 2.

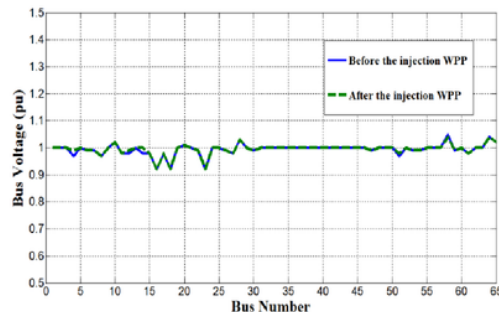

Fig. 2. Profile of voltage before and after WPP Jeneponto injection

Total losses in load flow simulation after WPP Jeneponto injection are active power of 60.411 MW and reactive power 272.256 MVAR. This has decreased losses as shown in Table I.

TABLE I. LOAD FLOW BEFORE AND AFTER WPP INJECTION

| Power flow & losses | Before injection | After injection |
|-------------------------------|------------------|-----------------|
| Total Generation | | |
| Active power (MW) | 1111.692 | 1110.409 |
| Reactive power (MVAR) | 612.905 | 607.328 |
| Total Load | | |
| Active power (MW) | 1050 | 1050 |
| Reactive power (MVAR) | 337.398 | 335.073 |
| Total Losses | | |
| Active power (MW) | 61.694 | 60.411 |
| Reactive power (MVAR) | 275.507 | 272.256 |
| Active Power Percentage (%) | 5.55% | 5.44% |
| Reactive Power Percentage (%) | 44.95% | 44.83% |

From Table I shows the total losses comparison before and after WPP injection, which was obtained before WPP injection of active power losses of 5.55 % and reactive power of 44.95 %. After WPP injection the active power losses drop to 5.27 % and reactive drops to 44.83 %, so the decrease in active power losses is 0.11% and the reactive power losses decrease by 0.12 % load flow after WPP injection.

A. Analyzing Dynamic Conditions Before WPP Jeneponto Injection (Fault on G1 Tallasa)

1) Rotor angle stability

The results of the stability of the rotor angle stability of the SULSELBAR system before the WPP Jeneponto power injection are shown in Fig. 3. The results of the stability of the combined cycle power plant is Sengkang PLTGU (G1) are used as reference angle, diesel power plants is Sungguminasa PLTD (G6), steam power plant is Barru PLTU (G7) and hydropower plant is Poso PLTA (G13) because the system uses various types of power generation with many different generating units so that a generator is chosen that has a different rotor angle.

In Fig. 3 the simulation results of the rotor angle graph of the time function can be expressed in table form as shown in Table II, which is when the system experiences interference in sec 1.

Fig. 3. Rotor angle graphic $f(t)$ before WPP Jeneponto injection

TABLE II. ROTOR STABILITY PRIOR TO WPP JENEPPONTO INJECTION

| Generators | Swing | Initial (Deg) | During Disturbance (Deg) | New (Deg) | Steady State (Sec) |
|------------|-------|---------------|--------------------------|-----------|--------------------|
| G1 | Max | 54.3 | 71.8 | 71.1 | 11.6 |
| G6 | Max | 24.3 | 41.3 | 41.1 | 10.7 |

| | | | | | |
|-----|-----|------|------|------|------|
| | Min | | 41.1 | | |
| G7 | Max | 29.9 | 47 | 46.7 | 10.5 |
| | Min | | 46.7 | | |
| G13 | Max | 17.8 | 35.8 | 34.6 | 9.1 |
| | Min | | 34.6 | | |

In Table II it can be seen that the angle of the rotor changes and can be stabilized with a new angle with recovery time after the disturbance is removed from the system at $t = 1.083$ sec.

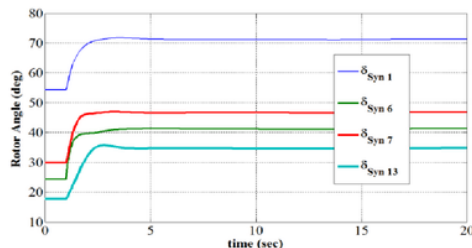
2) Frequency stability

The simulation results of frequency before injection are shown in Fig. 4. Before the frequency disturbance of the generator G1, G6, G7 and G13 are at a working frequency of 50 Hz, until there is a disturbance in sec 1.

From Fig. 4 the results of the frequency graph simulation of the time function can be expressed in table form, as shown in Table III which is when the system experiences a 1 sec fault.

Fig. 4. Frequency graph $f(t)$ before WPP Jeneponto injection

TABLE III. FREQUENCY STABILITY BEFORE WPP JENEPPONTO INJECTION

| Generators | Swing | During Disturbance (Hz) | Steady State (Hz) | Steady State (Sec) |
|------------|-------|-------------------------|-------------------|--------------------|
| G1 | Max | 50.1 | 50 | 2.5 |
| G6 | Max | 50.2 | 50 | 1.7 |
| G7 | Max | 50.1 | 50 | 2 |
| G13 | Max | 50.05 | 50 | 2.6 |

From Table III the frequency stability before injection, shows the frequency of oscillation and can be stabilized at a frequency of 50 Hz with a recovery time of G1 2.5 sec, G6 for 1.7 sec, G7 for 2 sec and G13 for 2.6 sec after the interference has been removed from the system.

3) Voltage stability

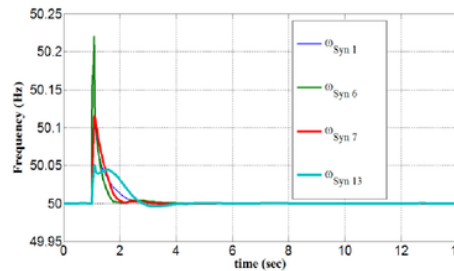
Stability The pre-injection voltage is shown in Fig. 5 for the Generator bus, Poso PLTA, Sungguminasa PLTD, Sengkang PLTGU and Barru PLTU, this generator bus before the disturbance all works at 1 pu voltage, until there is a disturbance at sec 1.

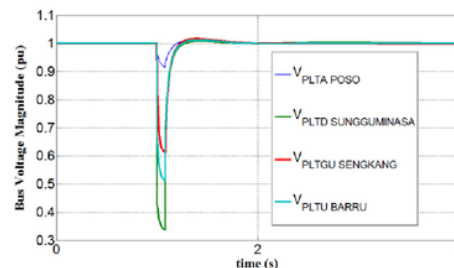
Fig. 5. Voltage graph $f(t)$ before WPP Jeneponto injection.

In Fig. 5 the results of the simulation of the voltage graph of the time function can be expressed in table form, as shown in Table IV which is when the system experiences a breakdown in sec 1.

TABLE IV. VOLTAGE STABILITY BEFORE WPP JENEPONTO INJECTION

| Bus | V (drop) (pu) | V (Steady State) (pu) | Time (Steady State) (sec) |
|-------------------|---------------|-----------------------|---------------------------|
| PLTA Poso | 0.92 | 1 | 1.7 |
| PLTD Sungguminasa | 0.34 | 1 | 1.6 |
| PLTGU Sengkang | 0.61 | 1 | 1.8 |
| PLTU Barru | 0.51 | 1 | 1.7 |

In Table IV Voltage stability before injection, voltage is dropped and can be stabilized at the working voltage 1 pu, with recovery time for bus Poso PLTA for 1.7 sec, Sungguminasa PLTD for 1.6 sec, Sengkang PLTGU for 1.8 sec and Barru PLTU for 1.7 sec.

B. Analyzing Dynamic Conditions after WPP Jeneponto Injection (Fault in GI Tallasa)

1) Rotor angle stability

Rotor angle stability after injection, with fault on GI Tallasa shown in Fig. 6, which is discussed on rotor angle on G1, G6, G7 and G13.

From Fig. 6 the result of rotor angle graph simulation can be put into table as shown in Table V in which the system is disturbed on sec 1.

In Table V it can be seen that rotor angle experience changes and can return to stabilize with a new angle in recovery time after breakdown is omitted from the system.

Fig. 6. Rotor angle graph $f(t)$ after WPP Jeneponto injection

TABLE V. STABILITY OF ROTOR ANGLE AFTER WPP JENEPONTO INJECTION

| Generators | Swing | Initial (Deg) | During disturbance (Deg) | New (Deg) | Steady state (Sec) |
|------------|------------|---------------|--------------------------|-----------|--------------------|
| G1 | Max Min | 54.3 | 72.1 | 72 | 10.1 |
| G6 | Max Min | 24.5 | 42.1 | 42.1 | 9.7 |
| G7 | Max Min | 30 | 47.7 | 47.7 | 9.8 |
| G13 | Max Min | 17.8 | 36.1 35.2 | 35.4 | 9.10 |

2) Frequency stability

The result of frequency simulation after injection is shown in Fig. 7. Before disturbance in frequency in

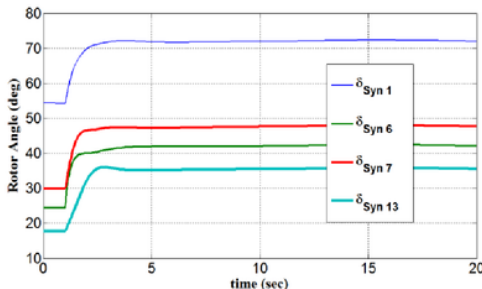
generator G1, G6, G7 and G13 is on working frequency which is 50Hz, so that disturbance happened in sec 1.

From Fig. 7 the result of frequency graph simulation the function of time can be put into table, as shown in Table VI where the system is disturbed at sec 1.

Fig. 7. Frequency graph $f(t)$ after WPP Jeneponto injection

TABLE VI. FREQUENCY STABILITY AFTER WPP JENEPONTO INJECTION

| Generators | Swing | During Disturbance (Hz) | Steady State (Hz) | Steady State (Sec) |
|------------|-------|-------------------------|-------------------|--------------------|
| G1 | Max | 50.1 | 50 | 2.3 |
| G6 | Max | 50.2 | 50 | 1.6 |
| G7 | Max | 50.1 | 50 | 1.8 |
| G13 | Max | 50.05 | 50 | 2.5 |

From Table VI frequency stability after injection, showed frequency is experiencing oscillation and can be stabilized on 50 Hz frequency with recovery time G1 2.3 sec, G6 for 1.6 sec, G7 for 1.8 sec and G13 for 2.5 sec after disturbance is omitted.

3) Voltage stability

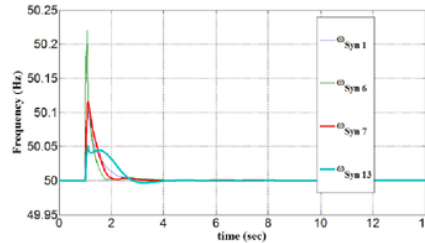
Voltage stability after injection is shown in Fig. 8 for bus generator Poso PLTA, Sungguminasa PLTD, Sengkang PLTGU and Barru PLTU, the bus generator before the disturbance worked properly in 1 pu voltage, that the disturbance happened in sec 1.

In Fig. 8 voltage graph simulation result can be put into table, as shown in Table VII in which the system is disturbed at sec 1.

Fig. 8. Voltage graph $f(t)$ after WPP Jeneponto injection

TABLE VII. VOLTAGE STABILITY AFTER WPP JENEPONTO INJECTION

| Bus | V (drop) (pu) | V (Steady state) (pu) | Time (Steady State) (Sec) |
|-------------------|---------------|-----------------------|---------------------------|
| PLTA Poso | 0.91 | 1 | 1.6 |
| PLTD Sungguminasa | 0.34 | 1 | 1.5 |
| PLTGU Sengkang | 0.61 | 1 | 1.7 |
| PLTU Barru | 0.51 | 1 | 1.6 |

In Table VII Voltage stability after injection, the voltage has dropped and can be stabilized at a working voltage of 1 pu, with recovery time bus Poso PLTA for 1.6 sec, Sungguminasa PLTD for 1.5 sec, Sengkang PLTGU for 1.7 sec and Barru PLTU for 1.6 sec. after

interference is removed from the system. Before the system enters the maximum time of 10 interruption, which is 0.083 sec from the time the fault occurs, the system is in the steady state area, so that it can operate safely and the power supply is maintained.

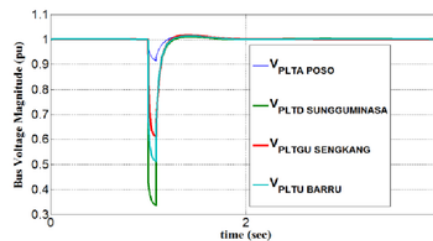
10
IV. CRITICAL CLEARING TIME

To determine the critical clearing time of the SULSELBAR power system before and after the WPP Jeneponto injection, it can be done by trial and error by varying the value of the interruption time. Stability before the injection was carried out stability simulation with a duration time of 0.1776 sec, 0.1778 sec and a time of disturbance when 25 the rotor angle experienced synchronous release, as shown in Fig. 9.

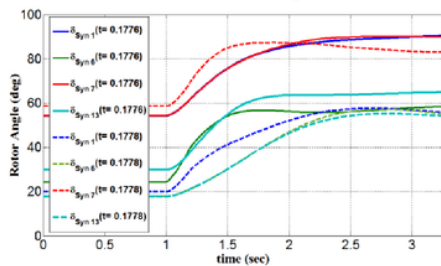

Fig. 9. Rotor angle clearing time graph before WPP Jeneponto injection

From Fig. 9 the critical clearing time before injection with interference on the GI Tallasa, shows the generator on the system will experience synchronous release in the interruption lasting for 0.1778 sec. Whereas after injection is done stability simulation with a duration of 0.1776 sec and 0.1889 sec the rotor angle experiencing synchronous release as shown in Fig. 10.

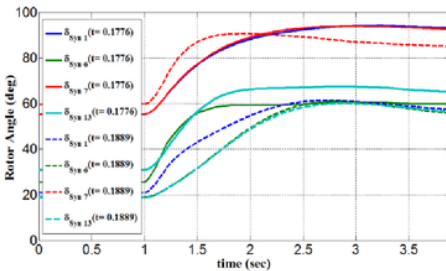

Fig. 10. Rotor angle clearing time graph after WPP Jeneponto injection

TABLE VIII. ROTOR ANGLE CLEARING TIME

| Generators | Critical clearing time | |
|------------|------------------------|-----------------------|
| | Before injection (sec) | After injection (sec) |
| G1 | 0.1776 | 0.1776 |
| | 0.1778 | 0.1889 |
| G6 | 0.1776 | 0.1776 |
| | 0.1778 | 0.1889 |
| G7 | 0.1776 | 0.1776 |
| | 0.1778 | 0.1889 |
| G13 | 0.1776 | 0.1776 |
| | 0.1778 | 0.1889 |

4
From Table VIII the critical clearing time of the system after injection of WPP Jeneponto has a longer time of

23
0.1889 sec compared to the critical clearing time of the system before the injection of WPP Jeneponto.

V. CONCLUSION

Injection effect of Jeneponto WPP to SULSEBAR power system in Indonesia is presented in this study. From results, it is concluded that impact of the WPP injection to steady state and dynamics stability conditions of the served system can improve voltage profile, and reduce active power losses of 0.11% and reactive power of 0.12%. Other results regarding dynamic stability analysis (rotor angle, frequency, and voltage stability) shown when a fault occurs with a duration of 0.823 sec the SULSELBAR power system will return to stable condition after transient oscillation. Critical clearing time before injection of the WPP with disturbances on Tallasa GI shown that rotor angle has experienced synchronous release when duration of the disturbance time is 0.1778 sec. Whereas after WPP injection with a duration of 0.1889 sec, the rotor angle experienced synchronous release.

ACKNOWLEDGMENT

The authors would like to offer his gratitude toward PT. PLN. (Persero) in Makassar on the contribution of providing data on SULSELBAR power system and also to the members of Power System Stability and Control Research Group (PSSC-RG) Department of Electrical Engineering, Hasanuddin University.

REFERENCES

- Y. S. Lim, E. T. Chok, K. H. Chua, and S. M. S. Liew, "Innovative fuzzy controller on island power systems with energy storage and renewable for minimum fuel consumption," *Int. Journal of Electrical and Electronic Engineering & Telecommunications*, vol. 7, no. 2, pp. 38-42, January 2018.
- P. S. Georgilakis, "Technical challenges associated with the integration of wind power into power systems," *Renewable and Sustainable Energy Reviews*, vol. 12, no. 3, pp. 852-863, April 2008.
- A. H. M. Achzab. (29 December 2017). Peran Mahasiswa Dalam Mendukung Rencana Umum Energi Nasional Sebagai Bentuk Kontribusi Nyata Dalam Agenda Indonesia Emas 2045. [Online]. Available: <https://medium.com/@adehilmymaulanaachzab/peran-mahasiswa-dalam-mendukung-rencana-umum-energi-nasional-sebagai-bentuk-kontribusi-nyata-8387b0de21c8>
- S. Humena, S. Manjang, and I. C. Gunadin, "Optimization economic power generation using modified improved PSO algorithm methods," *Journal of Theoretical and Applied Information Technology*, vol. 23, no. 2, pp. 522-530, November 2016.
- J. Wong and Y. S. Lim, "Experimental validation for dynamic fuzzy-controlled energy storage system to maximize renewable energy integration," *Int. Journal of Electrical and Electronic Engineering & Telecommunications*, vol. 7, no. 3, pp. 83-89, July 2018.
- Rencanan Umum Penyediaan Tenaga Listrik (RUPTL) tahun 2018-2027. Surat Keputusan Menteri Energi dan Sumber Daya Mineral (ESDM), Nomor 1567 K/21/MEM/2018, 2018.
- H. Saadat, *Power System Analysis*, 2nd ed. McGraw-Hill Press, 1999.
- J. J. Grainger and W. D. Stevenson, *Power System Analysis*, McGraw-Hill Education, 1994.

[9] I. C. Gunadin and M. Amin, "Determination of steady state stability margin using extreme learning machine 2 research method," *Wseas Trans. on Power System*, vol. 7, no. 3, pp. 91–103, July 2012.

[10] O. Goksu, R. Teodorescu, C. L. Bak, F. Iov, and P. C. Kjær, "Impact of wind power plant reactive current injection during asymmetrical grid faults," *IET Renew. Power Gener.*, vol. 7, no. 5, pp. 484–492, September 2013.

[11] M. Q. Duong, S. Leva, M. Mussetta, and K. H. Le, "A comparative study on controllers for improving transient stability of DFIG wind turbines during large disturbances," *Energies*, vol. 11, no. 3, p. 480, February 2018.

[12] I. C. Gunadin, A. Soeprijanto, and O. Penangsang, "Steady state stability assessment using extreme learning machine based on modal analysis," *Int. Review of Electrical Engineering*, vol. 7, no. 3, pp. 4532–4537, June 2012.

[13] Y. Kumar, "Study of power and renewable systems modeling and simulation tools," M.S. thesis, Dept. Elect. Eng., Toledo Univ., Toledo, Ohio, 2015.

[14] D. I. Döring, D. Dhua, S. Huang, and Q. Wu, "Voltage support in hybrid AC-DC grid by wind power plants and VSC," *Int. Journal of Electrical and Electronic Engineering & Telecommunications*, vol. 7, no. 4, pp. 165–171, October 2018.

[15] I. C. Gunadin, A. Soeprijanto, and O. Penangsang, "Real power generation scheduling to improve steady state stability limit in the Java-Bali 500 kV interconnection power system," *World Academy of Science, Engineering and Technology*, vol. 4, no. 12, pp. 1771–1775, December 2010.

[16] I. C. Gunadin, S. M. Said, and M. Irsan, "Determination of stability index of electrical power system using Rei-Dimo methods," *Journal of Theoretical and Applied Information Technology*, vol. 90, no. 1, pp. 161–167, August 2016.

[17] P. Kundur, J. Paserba, V. Ajjarapu, G. Andersson, A. Bose, C. Canizares, et al., "Definition and classification of power system stability IEEE/CIGRE joint task force on stability terms and definitions," *IEEE Trans. on Power Systems*, vol. 19, no. 3, pp. 1387–1401, August 2004.

[18] H. Suyono, K. M. Nor, and S. Yusof, "Transient stability program using component-based software engineering," in *Proc. TENCON 2005 - 2005 IEEE Region 10 Conf.*, 2005, pp. 1–6.

[19] H. Suyono, M. F. E. Pumomo, and H. Santoso, "Analysis of minihydro power and photovoltaic injection into the grid system," in *Proc. National Olimpiad and Int., Conf. on Education, Technology and Science*, 2013, pp. 208–212.

[20] S. Yamujala and M. Fatima, "Performance analysis of distributed generation on radial distribution networks – A case study," *Journal of Electrical Engineering*, vol. 19, no. 3, September 2018.

[21] P. B. Eriksen, T. Ackermann, H. Abildgaard, P. Smith, W. Winter, and J. M. R. Garcia, "System operation with high wind penetration," *IEEE Power and Energy Magazine*, vol. 3, no. 6, pp. 65–74, 2005.

[22] A. Ameur, K. Loudiyi, and M. Aggour, "Steady state and dynamic analysis of renewable energy integration into the grid using PSS/E software," in *Proc. 4th Int. Conf. on Power and Energy Systems Engineering*, Germany, 2017, pp. 119–125.

[23] M. Reza, J. G. Sloopweg, P. H. Schvemaker, W. L. Kling, and L. V. D. Sluis, "Investigation impact of distribution generation on transmission system stability," in *Proc. of IEEE Power Tech Conf.*, Bologna, Italy, 2003, pp. 1–7.

[24] A. M. Miah, "Real-time localized control of transient stability," *Int. Journal of Electrical and Electronic Engineering & Telecommunications*, vol. 7, no. 3, pp. 76–82, July 2018.

[25] F. E. P. Surusa, H. Suyono, and Wijono, "Analisis steady state dan dinamik pada perencanaan pengembangan pembangkit sistem gorontalo," *Jurnal Arus Elektro Indonesia*, vol. 2, no. 1, pp. 9–14, May 2016.

[26] B. Yang, V. Vittal, and G. T. Heydt, "Slow-coherency-based controlled islanding—A demonstration of the approach on the august 14, 2003 blackout scenario," *IEEE Trans. on Power Systems*, vol. 21, no. 4, pp. 1840–1847, November 2006.

[27] L. L. Grigsby, *Power System Stability and Control*, New York: Taylor and Francis Group, LLC, 2007.

[28] P. Kundur, *Power System Stability and Control*, New York, US: McGraw – Hill, Inc., 1994.

[29] Ronalyw. (August 30, 2018). Lumbung listrik, predikat baru untuk SULSEL. [Online]. Available: <http://beritakotamakassar.fajar.co.id/berita/2018/08/30/lumbung-listrik-predikat-baru-sulsel/>

[30] F. A. Muhammad. (November 12, 2017) Blackout di SULSEL berlangsung selama 11 jam 45 menit. [Online]. Available: <http://makassar.tribunnews.com/2017/11/12/blackout-di-sulsel-berlangsung-selama-11-jam-45-menit?page=2>



Indar Chaerab Gunadin received the Doctoral degree from Sepuluh Nopember Institute of Technology, Indonesia in 2013. He is a lecturer and researcher at Department of Electrical Engineering, Hasanuddin University. Currently, he is head of Power System Stability and Control research group (PSSC-RG) at Hasanuddin University. His interests are in power system stability, control design and dynamic load modeling, FACTS devices, artificial intelligence, renewable energy, and power electronic.



Eka Sanjaya Putra AZ received the Magister degree from Hasanuddin University, Indonesia in 2018. Currently, he is members of Power System Stability and Control research group (PSSC-RG) at Hasanuddin University. His interests power system stability, power generation and renewable energy.



Yusri Syam Akil obtained his Ph.D. in Computer Science and Electrical Engineering from Kumamoto University, Japan in 2013. He is a lecturer and researcher at Department of Electrical Engineering, Hasanuddin University. Currently, he is head of Distributed Generation, Energy and Environment research group (DGEE-RG) at Hasanuddin University. His interests include energy management, power demand analysis and forecasting, power system optimization, and renewable energy.



Steven Humena received the Magister degree from Hasanuddin University, Indonesia in 2016. He is a lecturer and researcher at Department of Electrical Engineering, Ichsan Gorontalo University. Currently, he is members of Power System Stability and Control research group (PSSC-RG) at Hasanuddin University, and the head of Electrical Engineering Laboratory at Ichsan Gorontalo University. His interests are in power system stability, renewable energy, optimization economic power generation, and artificial intelligence.

ORIGINALITY REPORT

% **15**
SIMILARITY INDEX

% **4**
INTERNET SOURCES

% **6**
PUBLICATIONS

% **12**
STUDENT PAPERS

PRIMARY SOURCES

1 Shah Arifur Rahman, Rajiv. K. Varma, Wayne H. Litzenberger. "Bibliography of FACTS applications for grid integration of wind and PV solar power systems: 2010–2013 IEEE Working Group report", 2014 IEEE PES General Meeting | Conference & Exposition, 2014
Publication % **1**

2 Submitted to Indian Institute of Technology, Kharagpure
Student Paper % **1**

3 Submitted to Universitas Jember
Student Paper % **1**

4 Submitted to University of Cape Town
Student Paper % **1**

5 Du Yeol Kim, Hajin Lee, Soon Ki Jeong. "Electrochemical Properties of Ball-Milled Zinc Hexacyanoferrate Cathode Material for Calcium Ion Batteries", Materials Science Forum, 2019
Publication % **1**

Submitted to University of Bradford

| | | |
|----|--|------|
| 6 | Student Paper | % 1 |
| 7 | Submitted to Lovely Professional University Student Paper | % 1 |
| 8 | Submitted to RMIT University Student Paper | % 1 |
| 9 | Submitted to Ibra College of Technology Student Paper | % 1 |
| 10 | Submitted to Institute of Graduate Studies, UiTM Student Paper | <% 1 |
| 11 | pserc.wisc.edu Internet Source | <% 1 |
| 12 | Submitted to Universitas Hasanuddin Student Paper | <% 1 |
| 13 | jurnaleccis.ub.ac.id Internet Source | <% 1 |
| 14 | eprints.qut.edu.au Internet Source | <% 1 |
| 15 | Submitted to The Hong Kong Polytechnic University Student Paper | <% 1 |
| 16 | Submitted to The University of Manchester Student Paper | <% 1 |

L. van der Sluis. "Impacts of distributed

17

generation penetration levels on power systems transient stability", IEEE Power Engineering Society General Meeting 2004 PES-04, 2004

Publication

<% 1

18

Submitted to Indian School of Mines

Student Paper

<% 1

19

Submitted to Coventry University

Student Paper

<% 1

20

Submitted to Universiti Tenaga Nasional

Student Paper

<% 1

21

Cheng Liu, Guowei Cai, Weichun Ge, Deyou Yang, Chuang Liu, Z.L. Sun. "Oscillation Analysis and Wide-Area Damping Control of DFIGs for Renewable Energy Power Systems Using Line Modal Potential Energy", IEEE Transactions on Power Systems, 2018

Publication

<% 1

22

smarc2net.eu

Internet Source

<% 1

23

Submitted to IIT Delhi

Student Paper

<% 1

24

A Siswanto, I C Gunadin, S M Said, A Suyuti. "Stability Improvement by Reducing Voltage Fluctuation using SVC in Penetration Wind Power System", IOP Conference Series: Materials Science and Engineering, 2019

<% 1

25

Submitted to North Dakota State University

Student Paper

<% 1

26

W. Freitas, J.C.M. Vieira, A. Morelato, W. Xu. "Influence of Excitation System Control Modes on the Allowable Penetration Level of Distributed Synchronous Generators", IEEE Transactions on Energy Conversion, 2005

Publication

<% 1

27

Submitted to Imperial College of Science, Technology and Medicine

Student Paper

<% 1

28

aip.scitation.org

Internet Source

<% 1

29

Submitted to Tshwane University of Technology

Student Paper

<% 1

30

export.arxiv.org

Internet Source

<% 1

31

Submitted to University of Leeds

Student Paper

<% 1

32

Maryam Bahramipanah, Saeed Afsharnia, Azin Aslani. "A study on power system's transient stability in determination of the appropriate generator type for wind turbines: Comparison between fixed-speed induction generator

<% 1

equipped with energy storage system and doubly-fed induction generator", 2011 10th International Conference on Environment and Electrical Engineering, 2011

Publication

33

Submitted to University of Queensland

Student Paper

<% 1

34

core.ac.uk

Internet Source

<% 1

35

energyexemplar.com

Internet Source

<% 1

36

Juergen Stich, Thomas Hamacher, Marcus Muller, Holger C. Hesse, Andreas Jossen. "Sustainable power supply options for large islands — A case study for Belitung Island", 2016 IEEE Innovative Smart Grid Technologies - Asia (ISGT-Asia), 2016

Publication

<% 1

37

www.tdx.cat

Internet Source

<% 1

38

www.uwig.org

Internet Source

<% 1

39

ieeexplore.ieee.org

Internet Source

<% 1

40

Arechkik Ameer, Khalid Loudiyi, Mohammed

<% 1

Aggour. "Steady State and Dynamic Analysis of Renewable Energy Integration into the Grid using PSS/E Software", Energy Procedia, 2017

Publication

EXCLUDE QUOTES ON

EXCLUDE
BIBLIOGRAPHY ON

EXCLUDE MATCHES < 5
WORDS